

9450 | **Alternator, Secondary Countershaft, Feeder Conveyor, Shoe, Straw Walker and Conveyor Augers (Right-Hand Side)**

Key	Qty.	Serial No.	Part No.	Description
1	1		R502418	Alternator (95 amp)
	1		R502417	Alternator (185 amp)
2	1		H128010	Secondary countershaft
3	1		H131169	Shoe, walker, and conveyor augers

9550, 9550SH |

Key	Qty.	Serial No.	Part No.	Description
1	1		H163515	Alternator (95 amp)
	1		H166870	Alternator (185 amp)
2	1		H128010	Secondary countershaft
3	1		H131169	Shoe, walker, and conveyor augers

9650 |

Key	Qty.	Serial No.	Part No.	Description
1	1	(-695300)	H163515	Alternator (95 amp)
	1	(-695300)	H166870	Alternator (185 amp)
	1	(695301-)	R164820	Alternator (185 amp)
2	1		H128010	Secondary countershaft
3	1		H131169	Shoe, walker, and conveyor augers

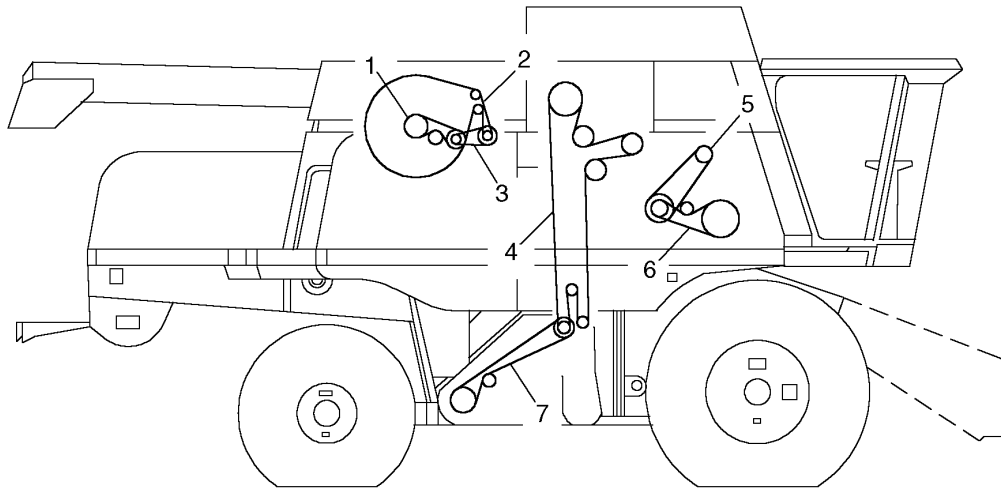

9450 Cooling Fan, Rotary Screen, Air Conditioning, Clean Grain Elevator, Cylinder Intermediate Drive, Cylinder Drive, Lower Tailings Auger and Elevator

Key	Qty.	Serial No.	Part No.	Description
1	1		H132808	Cooling fan
2	1	(-695100)	H145158	Rotary screen
	1	(695101-)	H175632	Rotary screen
3	1		H146636	Rotary screen drive
4	1		H141166	Clean grain elevator
5	1		H210476	Cylinder intermediate drive (150-980 RPM)
	1		H137670	Cylinder intermediate drive (300-1,000 RPM)
6	1		H115881	Cylinder drive (240-960 RPM standard)
	1		H145994	Cylinder drive (extended range)
7	1		N110085	Lower tailings auger and elevator
-	1		H101813	Air conditioning compressor (not shown)

9550, 9550SH

Key	Qty.	Serial No.	Part No.	Description
1	1		H160405	Cooling fan
2	1	(-695200)	H145158	Rotary screen
	1	(695201-)	H175632	Rotary screen
3	1		H160406	Rotary screen drive
4	1		H141166	Clean grain elevator
5	1		H210476	Cylinder intermediate drive (150-980 RPM)
	1		H137670	Cylinder intermediate drive (300-1,000 RPM)
6	1		H115881	Cylinder drive (240-960 RPM)
	1		H118618	Cylinder drive (150-500 RPM)
7	1		N110085	Lower tailings auger and elevator
-	1		H163515	Air conditioning compressor (not shown)

9650

Key	Qty.	Serial No.	Part No.	Description
1	1	(-695300)	H153297	Cooling fan
	1	(695301-)	H177186	Cooling fan
2	1	(-655300)	H145158	Rotary screen
	1	(695301-)	H175632	Rotary screen
3	1	(-695300)	H160406	Rotary screen drive
	1	(695301-)	H146636	Rotary screen drive
4	1		H141166	Clean grain elevator
5	1		H210476	Cylinder intermediate drive
6	1		H115881	Cylinder drive (240-960 RPM)
	1		H118618	Cylinder drive (150-500 RPM)
7	1		N110085	Lower tailings auger and elevator
-	1		H163515	Air conditioning compressor (not shown)

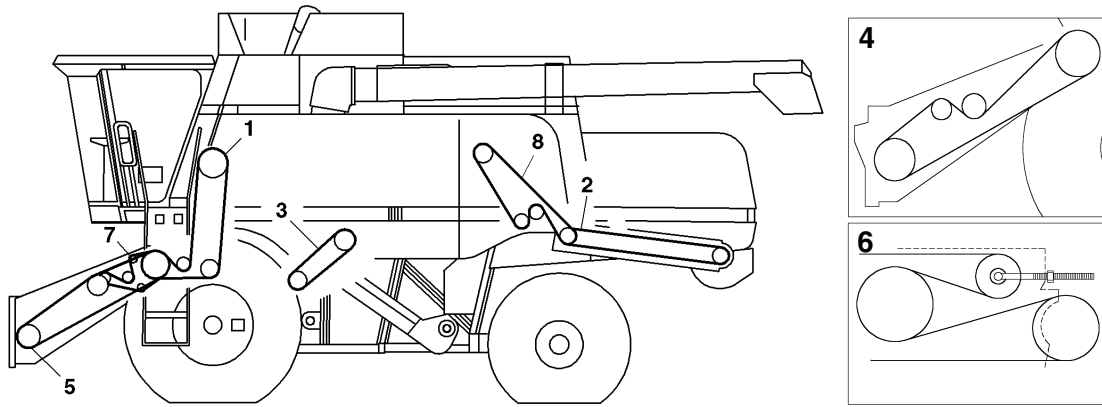

9450 Header and Reel Pump, Unloading Augers, Cleaning Fan, Feeder House and Straw Chopper (Left-Hand Drive)

Key	Qty.	Serial No.	Part No.	Description
1	1		H151952	Header and reel pump (standard)
2	1		H101436	Straw chopper (long rear)
			H27433	Straw chopper (short rear)
3	1		H152146	Cleaning fan (750-1,350 RPM)
			H152180	Cleaning fan (490-980 RPM)
4	1	(-700100)	H126345	Fixed speed feeder house with reverser
		(700101-)	H156796	Fixed speed feeder house with reverser
5	1	(-700100)	H161648	Variable speed feeder house
		(700101-)	H205167	Variable speed feeder house
6	1		Z33774	Straw spreader
7	1		H171386	Air flow drive
8	1		H157726	Engine to PTO jackshaft (upper)

9550

Key	Qty.	Serial No.	Part No.	Description
1	1		H151952	Header and reel pump (standard)
			H155998	Header and reel pump (high-capacity)
2	1		H175434	Straw chopper (fine cut)
			H22529	Straw chopper (fine cut baling)
			H160654	Straw chopper (standard)
			H23950	Straw chopper (standard baling)
3	1		H152146	Cleaning fan (750-1,350 RPM)
			H152180	Cleaning fan (490-980 RPM)
4	1	(-700200)	H126345	Fixed speed feeder house with reverser
		(700201-)	H156796	Fixed speed feeder house with reverser
5	1	(-700200)	H161648	Variable speed feeder house
		(700201-)	H205167	Variable speed feeder house
			H218728	Variable speed feeder house (high-capacity)
6	1		H128234	Straw spreader
7	1		H171386	Air flow drive
8	1		H157726	Engine to PTO jackshaft (upper)

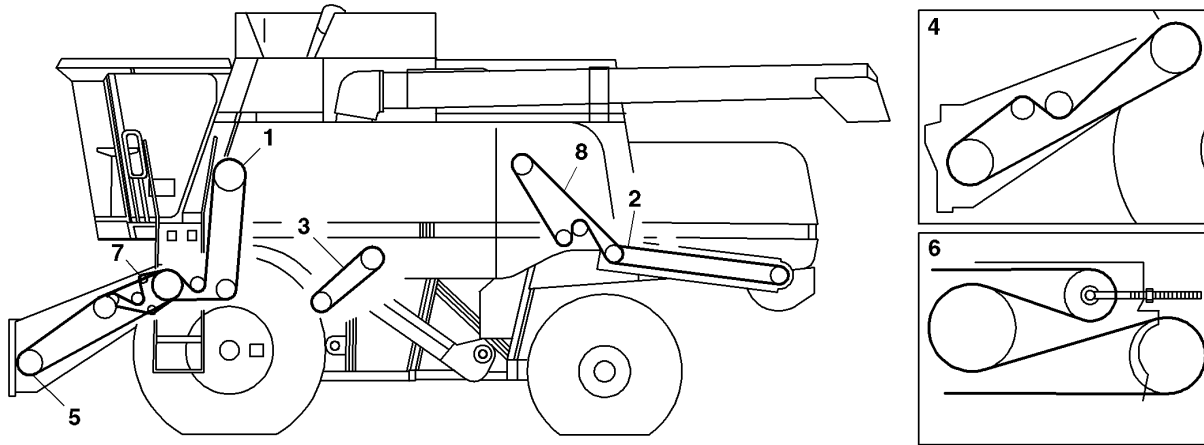

9650 Header and Reel Pump, Unloading Augers, Cleaning Fan, Feeder House and Straw Chopper (Left-Hand Drive)

Key	Qty.	Serial No.	Part No.	Description
1	1		H151952	Header and reel pump (standard)
	1		H155998	Header and reel pump (high-capacity)
2	1		H175434	Straw chopper (fine cut)
	1		H22529	Straw chopper (fine cut baling)
	1		H160654	Straw chopper (standard)
	1		H23950	Straw chopper (standard baling)
	1		H152146	Cleaning fan (750-1,350 RPM)
3	1		H152180	Cleaning fan (490-980 RPM)
	1	(-700300)	H126345	Fixed speed feeder house with reverser
4	1	(700301-)	H156796	Fixed speed feeder house with reverser
	1	(-700300)	H161648	Variable speed feeder house
5	1	(700301-)	H205167	Variable speed feeder house
	1		H218728	Variable speed feeder house (high-capacity)
6	1		H128234	Straw spreader
7	1		H171386	Air flow drive
8	1		H157726	Engine to PTO jackshaft (upper)

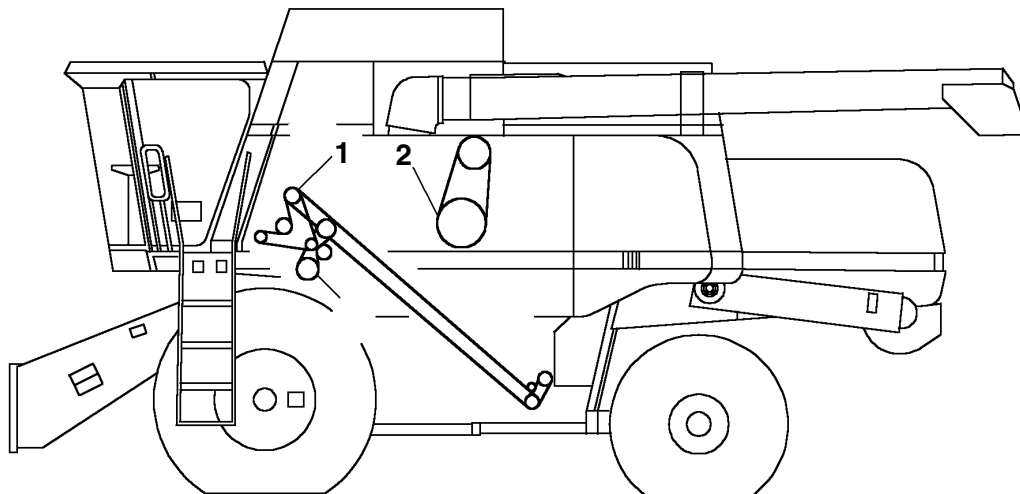

9450, 9550, 9550SH, 9650 Tailings Auger, Beater and Unloading System (Left-Hand Side)

Key	Qty.	Serial No.	Part No.	Description
1	1		AH139436	Beater drive (100%)
	1		AH163931	Beater drive (75%)
2	1		AH158880	Unloading system