

**9560STS** | **Clean Grain Elevator, Jackshaft, Feed Accelerator, Shoe Fan and Conveyor Augers, Cleaning Fan, Tailing Augers and Elevator**

Key	Qty.	Serial No.	Part No.	Description
1	1		H218645	Clean grain elevator
2	1		H154723	R.H. jackshaft, rear
3	1		AH202773	R.H. jackshaft, front
4	1	(715301- )	H211581	Feed accelerator, standard speed
		( -715300)	H221731	Feed accelerator, standard speed
	1		H221732	Feed accelerator, slow speed
5	1		H175587	Shoe fan and conveyor augers
6	1		H206048	Cleaning fan
	1		H211601	Cleaning fan, slow speed (Sub for H206049)
7	1		H154731	Tailings auger and elevator
	1		A-C72	Tailings auger and elevator (edible bean)

**9660STS, 9760STS** |

Key	Qty.	Serial No.	Part No.	Description
1	1		H218645	Clean grain elevator
2	1		H154723	R.H. jackshaft, rear
3	1		AH150678	R.H. jackshaft, front
	1		A-C144	R.H. jackshaft, front (edible bean)
4	1	(715301- )	H211581	Feed accelerator, standard speed
		( -715300)	H221731	Feed accelerator, standard speed
	1		H221732	Feed accelerator, slow speed
	1		H221733	Feed accelerator, high speed
5	1		H175587	Shoe fan and conveyor augers
6	1		H206048	Cleaning fan
	1		H211601	Cleaning fan, slow speed
7	1		H154731	Tailings auger and elevator
	1		A-C72	Tailings auger and elevator (edible bean)

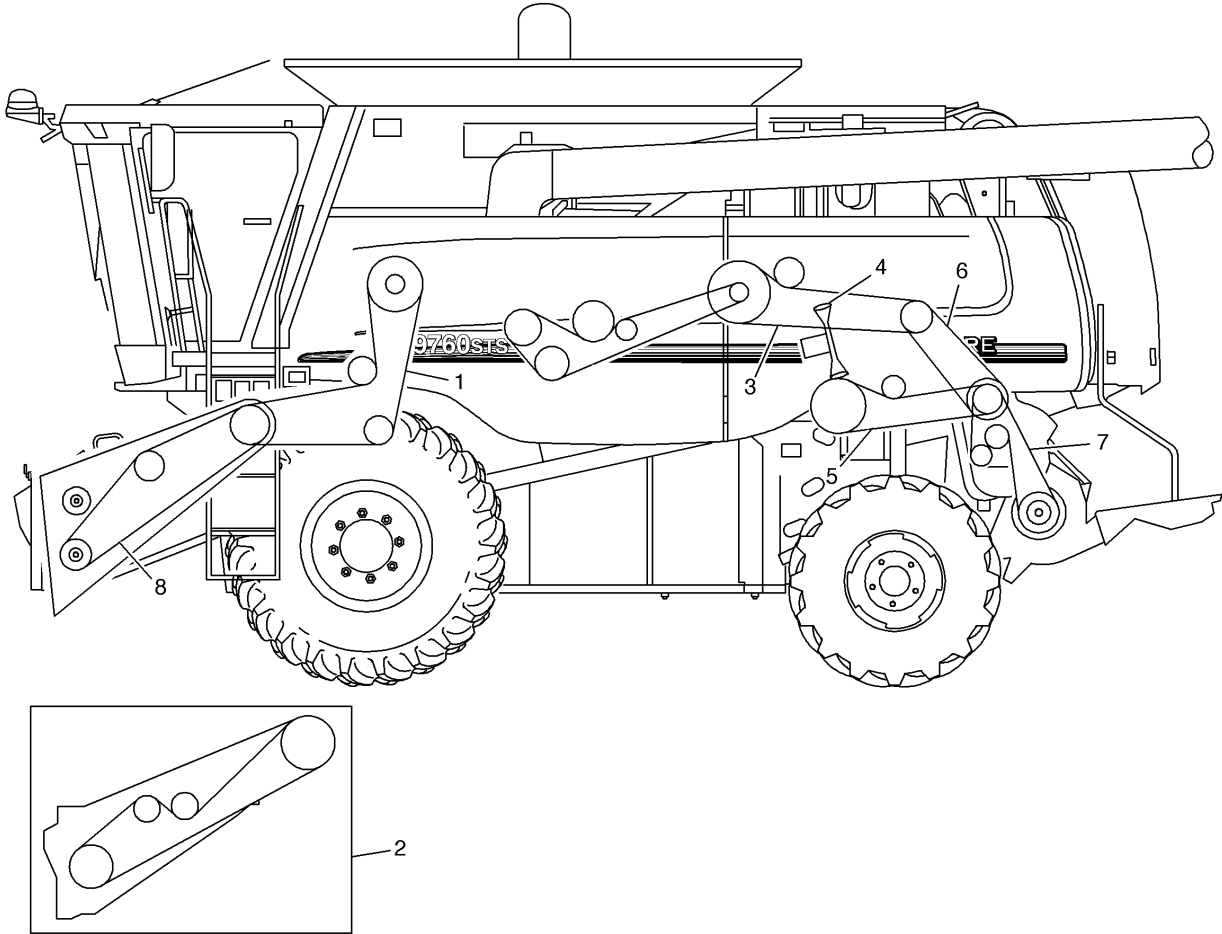

**9560STS Header and Reel Pump, Unloading Auger System, Variable Rotor Drive, Discharge Beater, Countershaft, Straw Chopper, Feeder House**

Key	Qty.	Serial No.	Part No.	Description
1	1		H126345	Header and reel pump (standard capacity)
	1		H209507	Header and reel pump (high capacity)
2	1		H126345	Fixed speed feeder house
3	1		AH160080	Unloading auger system
4	1		H169449	Variable rotor drive
5	1		H168301	Discharge beater
6	1		H157514	Countershaft, discharge beater and chopper
7	1		H204747	Straw chopper
8	1		H201334	Variable drive feeder house (standard capacity)
	1		H218726	Variable drive feeder house (high capacity)

**9660STS**

Key	Qty.	Serial No.	Part No.	Description
1	1		H156796	Header and reel pump (standard capacity)
	1		H156541	Header and reel pump (high capacity)
2	1		H203474	Fixed speed feeder house
3	1		AH160080	Unloading auger system
4	1		H169449	Variable rotor drive
5	1		H168301	Discharge beater
6	1		H157514	Countershaft, discharge beater and chopper
7	1		H204747	Straw chopper
8	1		H201334	Variable drive feeder house (standard capacity)
	1		H218726	Variable drive feeder house (high capacity)

**9760STS**

Key	Qty.	Serial No.	Part No.	Description
1	1		H156796	Header and reel pump (standard capacity)
	1		H156541	Header and reel pump (high capacity)
2	1		H203474	Fixed speed feeder house
3	1		AH160080	Unloading auger system
4	1		H169449	Variable rotor drive
5	1		H168301	Discharge beater
6	1		H157514	Countershaft, discharge beater and chopper
7	1		H204747	Straw chopper
8	1		H218726	Variable drive feeder house (high capacity)

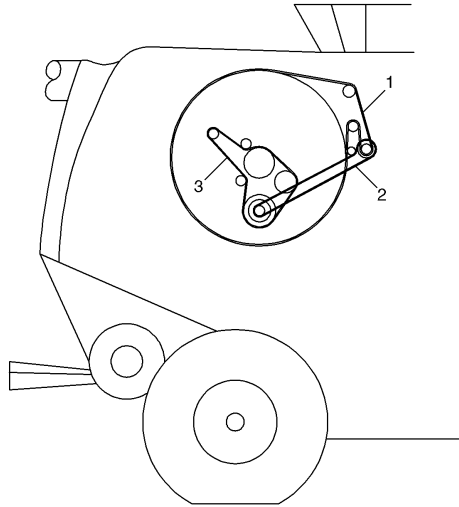

**9560STS | Rotary Screen Drive, Alternator**

Key	Qty.	Serial No.	Part No.	Description
1	1		H175632	Rotary screen drive (screen side)
2	1		H201498	Rotary screen drive (engine side)
3	1		R135606	Alternator (95 amp)
	1		R135609	Alternator (185 amp)

**9660STS, 9760STS**

Key	Qty.	Serial No.	Part No.	Description
1	1		H175628	Rotary screen drive (screen side)
2	1		H206807	Rotary screen drive (engine side)
3	1		R135606	Alternator (95 amp)
	1		R135609	Alternator (185 amp)