

**Alternator, Secondary Countershaft and Conveyor Augers**

Key	Qty.	Serial No.	Part No.	Description
1	1	( -695400)	H163515	Alternator (95 amp)
	1	( -695400)	H166870	Alternator (185 amp)
	1	(695401- )	R164820	Alternator (185 amp)
2	1		H128010	Secondary countershaft
3	1		H131169	Conveyor auger, sieve, and chaffer

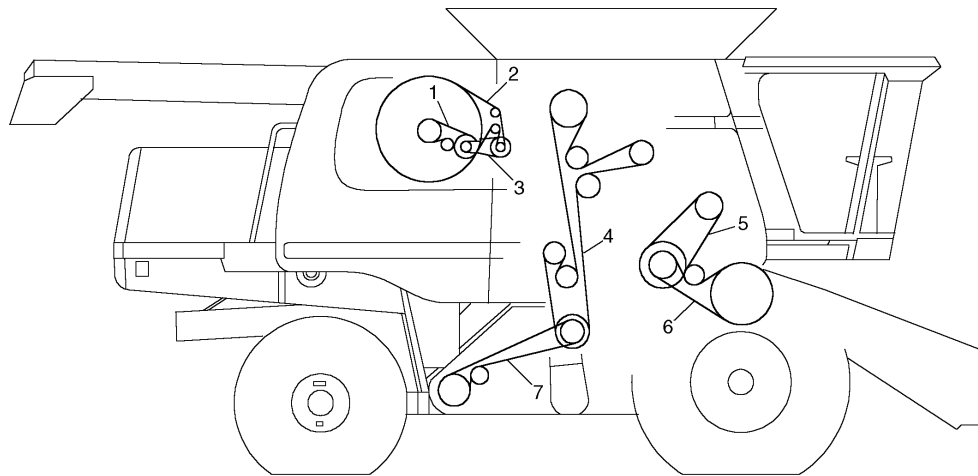

**Cooling Fan, Rotary Screen, Clean Grain Elevator, Cylinder Intermediate Drive, Cylinder Drive , Lower Tailings Auger and Elevator**

Key	Qty.	Serial No.	Part No.	Description
1	1	( -695400)	H160405	Cooling fan
	1	(695401- )	H177186	Cooling fan
2	1	( -695400)	H145158	Rotary screen
	1	(695401- )	H175632	Rotary screen
3	1	( -695400)	H160406	Rotary screen drive
	1	(695401- )	H146636	Rotary screen drive
4	1		H141166	Clean grain elevator
5	1		H210476	Cylinder intermediate drive (2,290 E.L.)
	1		H137670	Cylinder intermediate drive (2,270 E.L.)
6	1		H145994	Cylinder drive (2,270 E.L.)
	1		H118618	Cylinder drive (2,700 E.L.)
	1		H115881	Cylinder drive (2,830 E.L.)
7	1		N110085	Lower tailings auger and elevator

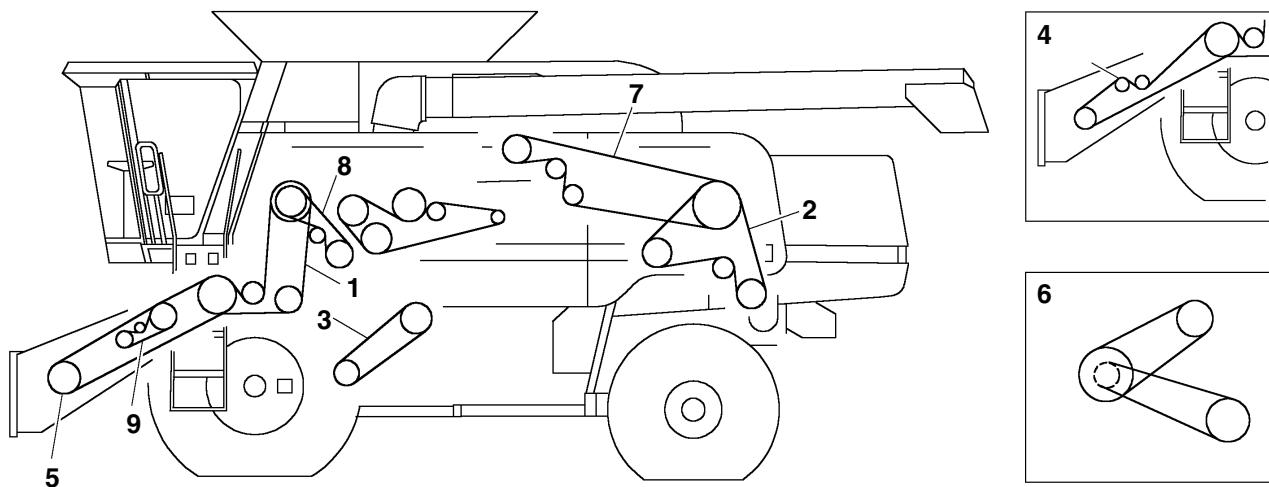

**Header and Reel Pump, Unloading Augers, Straw Chopper, Cleaning Fan, Feeder House and Straw Spreader (Left-Hand Drives)**

Key	Qty.	Serial No.	Part No.	Description
1	1		H151952	Header and reel pump (standard capacity)
	1		H155998	Header and reel pump (high-capacity)
2	1		H162727	Chopper drive
3	1		H152146	Cleaning fan (750-1,350 RPM)
	1		H152180	Cleaning fan (490-980 RPM)
4	1	( -700400)	H126345	Fixed speed feeder house w/reverser
	1	( 700401- )	H156796	Fixed speed feeder house w/reverser
5	1		H218728	Variable speed feeder house (high-capacity)
	1	( -700400)	H161648	Variable speed feeder house (standard capacity)
	1	( 700401- )	H205167	Variable speed feeder house (standard capacity)
6	1		H164870	Straw spreader (upper)
	1		P49604	Straw spreader (lower)
7	1		H163106	Tine separator drive
8	1		H139963	Overshot beater drive
	1		H165708	Overshot beater drive (740-1,170 RPM)
	1		E16774	Overshot beater drive (400 RPM slowdown kit)
	1		N121116	Overshot beater drive (700 RPM slowdown kit)
9	1		H164452	Air flow drive

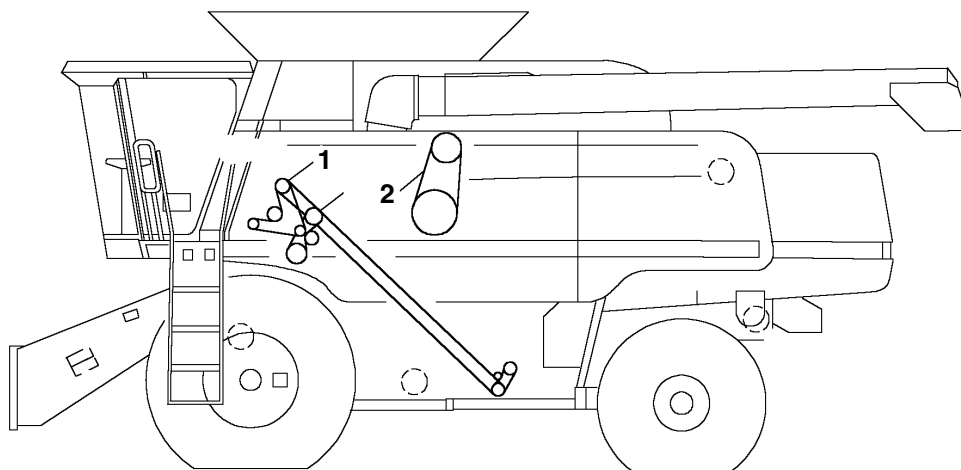

**Stripper Beater Drive and Unloading System**

Key	Qty.	Serial No.	Part No.	Description
1	1		H165708	Stripper beater drive
2	1		AH158880	Unloading system